

LAND LEVELING



# AUTOMATED LAND LEVELING

LASER LAND LEVELING SYSTEM FOR AGRICULTURE



## Self-leveling laser automatically controls scraper elevation

- Improves crop establishment
- Reduces weed problems
- Improves crop consistency
- Improves efficiency of water use

# AUTOMATED LAND LEVELING



## RL-H5A rugged, high accuracy laser transmitter with severe quality control

The RL-H5A provides:  $\pm 1.5\text{mm}@30\text{m}$  ( $\pm 10$  arc-seconds) of self leveling accuracy over an 900m diameter area, the longest working range in its class. IP66 rating for dust and water resistance provides all weather dependability.

### SPECIFICATIONS

LS-B110AG Receiver	
Vertical Detection Range	175mm
Detection Angle	360°
Detection Accuracy	$\pm 3\text{mm}$
Dust and Water Protection	IP66 (IEC 60529)
Power	10VDC to 30VDC external
Operating Temperature	-20°C to +50°C
Dimensions	158(L) x 166(W) x 357(H)mm (w/Mechanical Clamp)
Weight	2.0kg

RL-H5A	
Operating range	900 m diameter (W/LS-B110AG)
Leveling Accuracy	$\pm 1.5\text{mm}@30\text{m}$ (W/LS-B110AG)
Self-leveling range:	$\pm 5^\circ$
Manual slope settable range	$\pm 5^\circ$ (When the instrument is installed on the 0° surface)
Laser source:	Laser diode (Visible, 635 nm) CDRH (FDA) Class IIIa, IEC Class 3R
Rotational speeds	600 r.p.m
Status alerts	Hi and low battery
Dust and water resistance	IP66 (IEC60529: 2001)
Operating temperature	-20 to 50°C (-4 to 122°F)
Size	172(W) x 211(D) x 205(H) mm
Weight	External power supply type 1.8 kg (4.0 lbs) (with DD-79)

### Connection diagram

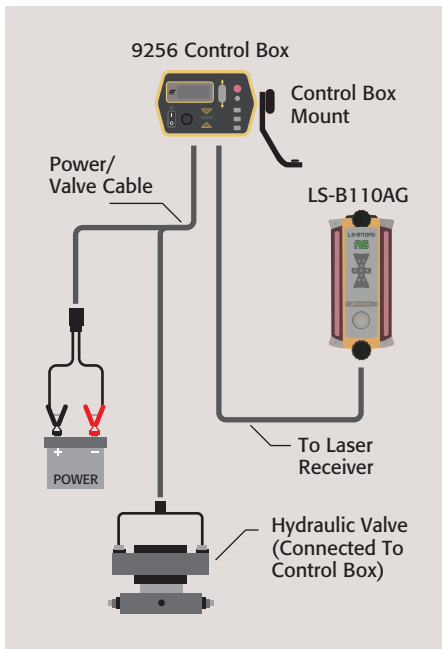

### System Configuration

#### 9256 CONTROL BOX

- Current-regulated proportional valve outputs
- Tough, environmentally sealed elastomer buttons
- Bright, 3-color LED grade lights automatically adjust lighting conditions



#### LASER RECEIVER LS-B110AG

- Highly visible color LED display
- Long working range
- Wide 175mm beam detection range
- 360° reception



Single slope capability

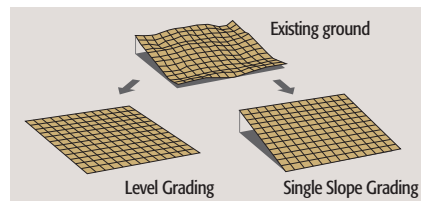

#### LASER TRANSMITTER RL-H5A

- Fast, automatic self-leveling
- Simple, intuitive manual slope-match capability
- Dual handles, rugged construction, and long battery life



### TOPCON CORPORATION

75-1 Hasunuma-cho, Itabashi-ku, Tokyo 174-8580, Japan  
www.topcon.co.jp

<Contact to>

#### Topcon Sokkia India Private Limited

Unit No.101 to 106A, 1st Floor, ABW Tower, MG Road, Sector-25,  
IFFCO Chowk, Gurgaon, Haryana-122001,India  
Phone: 91-124-484-7676  
Email : sales@topconsokkia.ind.in  
Web : http://www.topconsokkia.ind.in/

©2019 Topcon Corporation All rights reserved. P-122-1 TSI

- Specifications may vary by region and are subject to change without notice.  
- Other trademarks and trade names are those of their respective owners.

Your local Authorized Dealer is: